

Water Treatment



GEMINI P30

POMPE PNEUMATICHE



Caratteristiche principali

- **MATERIALI DI COSTRUZIONE: PP, POMC, PVDF, AISI 316, ALLUMINIO**
- **CAPACITÀ AUTOADESCANTE A SECCO FINO A 6M**
- **FUNZIONAMENTO A SECCO ILLIMITATO**
- **CIRCUITO PNEUMATICO ANTISTALLO E DI FACILE MANUTENZIONE**
- **POSSIBILITÀ DI REGOLAZIONE DI: PORTATA, PREVALENZA E VELOCITÀ.**
- **MOLTEPLICI VARIANTI DI INSTALLAZIONI E CONFIGURAZIONI**
- **CERTIFICAZIONI ATEX PER ZONA 1 E 2 IN TUTTE LE VERSIONI**
- **COPERCHIO DI SCARICO CON CONNESSIONI PER VARI UTILIZZI**
- **POMPAGGIO DI FLUIDI IN PRESENZA DI PARTI SOLIDE ED IN SOSPENSIONE**
- **POSSIBILITÀ DI FUNZIONARE A SECCO SENZA SUBIRE DANNI**

Water Treatment



Principali applicazioni

- **Produzione chimica e petrolchimica e trasformazione di prodotti di base**
- **Industria tessile**
- **Industria alimentare, conserviera, casearia, delle bevande ed oli**
- **Industria ecologica, smaltimento rifiuti , trattamento di fumi e acque e industria di stampa flessografica e fotografica**
- **Industria conciaria**
- **Estrazione**
- **Industria automobilistica e automotiva in generale**
- **Industria ceramica, vetro e porcellana**
- **Industria orafa**
- **Industria cartaria**
- **Industria elettronica e circuiti stampati**
- **Industria galvanotecnica, decappaggio, sgrassaggio e trattamento dei metalli in generale**
- **Industria di colori e vernici**
- **Industria petrolifera**
- **Industria per la produzione di fertilizzanti**
- **Industria metallurgica**
- **Industria del biodiesel , produzione di energia e accumulatori**
- **Industria dei detersivi industriali**
- **Industria farmaceutica**

Esempi di installazioni



Water Treatment



Dimensioni

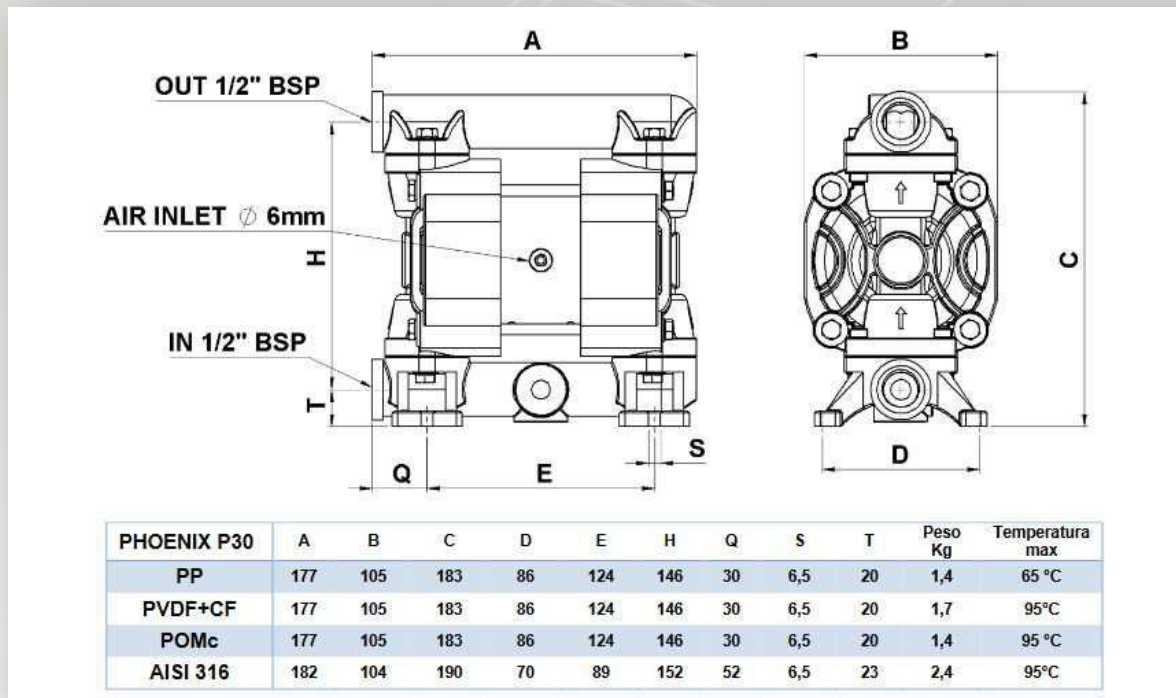

Specifiche

- CONNESSIONI: 1/2" BSP**
- ATTACCO ARIA: 6mm**
- PORTATA MASSIMA: 35 lt/min**
- PRESSIONE MASSIMA: 8 Bar**
- PREVALENZA MASSIMA: 80 Mt**
- MAX ASPIRAZIONE NEG. A SECCO: 5 mt**
- MAX ASPIRAZIONE NEG. INVASATA: 9,8 mt**
- PASSAGGIO SOLIDI: 3,5 mm**
- RUMOROSITA': 65 dB**
- CILINDRATA PER CICLO: 50cc**
- VISCOSITA': 15.000 cps**

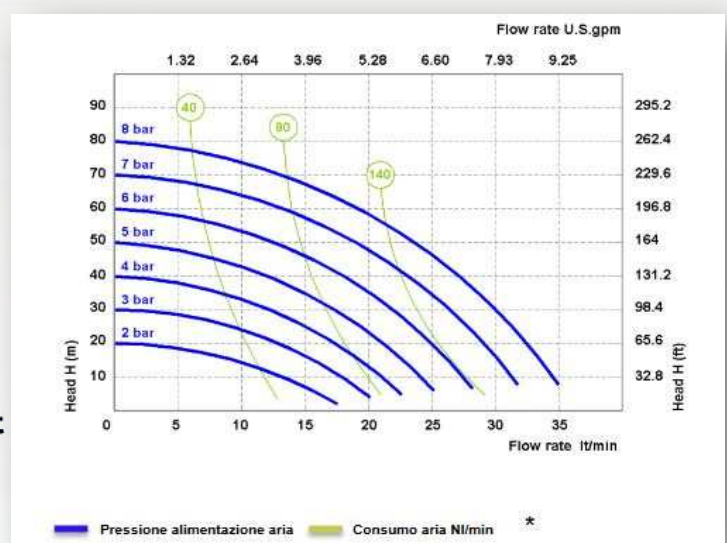

Water Treatment

Accessori



AIR REGULATION KIT

Adjust and set air pressure and air flow-rate with a filter regulator, pressure gauge and air valve unit.



SWITCH VALVES

Remotely start and stop with a solenoid or pneumatic valve for the pump's air.



STROKE COUNTER

Count the number of strokes, connected to a control. It allows various type of monitoring.



DIAPHRAGM FAILURE DETECTION

The Electronic Leak Detector provide a signal via warning lights, an audible alarm, and the pump can be shut down.



PNEUMATIC BATCH CONTROL "START & STOP"

Pneumatic batcher can control any pump allowing you to set the cycles amount.



BASKET STRAINER FILTERS IN PP

Installed on the suction of the pumps, protects them from suspended solids and impurity.



INOX TROLLEY

It makes transportable pumps



ANTI VIBRATION FEET KIT

Reduces physical vibration from AOD pump operation.



PP, PVDF, ALU, SS NOZZLE

Dispenser to delivery control and batching.



VALVES, FITTINGS AND CONNECTIONS IN PP, PVC, INOX



REINFORCED PVC HOSE

With metal reinforcement for suction/discharge, also food-grade.



FLANGE CONNECTION KIT

Adapt a pump from BSP type connection to flanges with this kit.