

Water Treatment



GEMINI P18

POMPE PNEUMATICHE



Principali caratteristiche

- MATERIALI DI COSTRUZIONE: PP, POMC, PVDF, AISI 316, ALLUMINIO
- CAPACITÀ AUTOADESCANTE A SECCO FINO A 6M
- FUNZIONAMENTO A SECCO ILLIMITATO
- CIRCUITO PNEUMATICO ANTISTALLO E DI FACILE MANUTENZIONE
- POSSIBILITÀ DI REGOLAZIONE DI: PORTATA, PREVALENZA E VELOCITÀ.
- MOLTEPLICI VARIANTI DI INSTALLAZIONI E CONFIGURAZIONI
- CERTIFICAZIONI ATEX PER ZONA 1 E 2 IN TUTTE LE VERSIONI
- COPERCHIO DI SCARICO CON CONNESSIONI PER VARI UTILIZZI
- POMPAGGIO DI FLUIDI IN PRESENZA DI PARTI SOLIDE ED IN SOSPENSIONE
- POSSIBILITÀ DI FUNZIONARE A SECCO SENZA SUBIRE DANNI

Water Treatment

Principali applicazioni



- **Produzione chimica e petrolchimica e trasformazione di prodotti di base**
- **Industria tessile**
- **Industria alimentare, conserviera, casearia, delle bevande ed oli**
- **Industria ecologica, smaltimento rifiuti , trattamento di fumi e acque e industria di stampa flessografica e fotografica**
- **Industria conciaria**
- **Estrazione**
- **Industria automobilistica e automotiva in generale**
- **Industria ceramica, vetro e porcellana**
- **Industria orafa**
- **Industria cartaria**
- **Industria elettronica e circuiti stampati**
- **Industria galvanotecnica, decappaggio, sgrassaggio e trattamento dei metalli in generale**
- **Industria di colori e vernici**
- **Industria petrolifera**
- **Industria per la produzione di fertilizzanti**
- **Industria metallurgica**
- **Industria del biodiesel , produzione di energia e accumulatori**
- **Industria dei detergenti industriali**
- **Industria farmaceutica**

Esempio di installazione



Water Treatment

Dimensioni

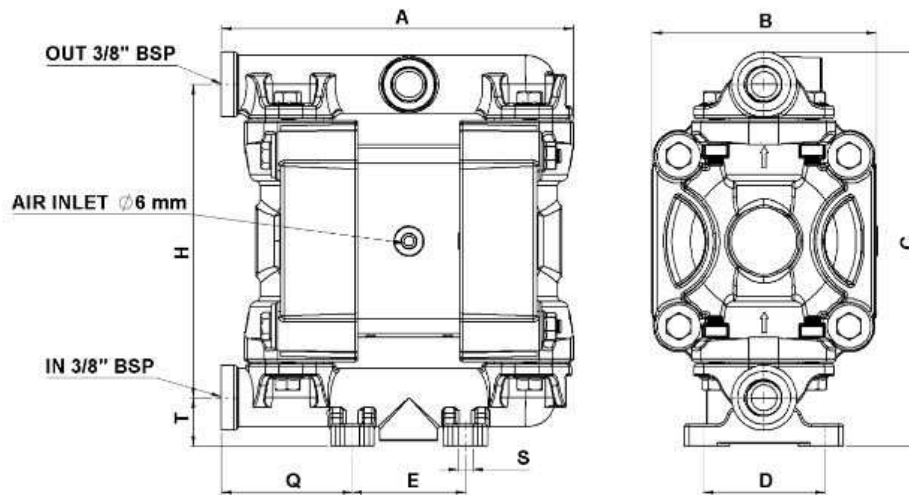

PHOENIX P18	A	B	C	D	E	H	Q	S	T	Peso Kg	Temperatura max
PP	146	93	164	50	47	130	55	6	20	1,1	65 °C
PVDF+CF	146	93	164	50	47	130	55	6	20	1,4	95 °C
POMc	146	93	164	50	47	130	55	6	20	1,1	95 °C
AISI 316	148	85	153	47	51	122	55	6	18	2,1	95 °C

Specifiche

CONNESSIONI :3/8" BSP
ATTACCO ARIA: 6 mm
PORTATA MASSIMA: 20 lt/min
PRESSIONE MASSIMA: 8 bar
PREVALENZA MASSIMA: 80 m
MAX ASPIRAZIONE NEG. A SECCO: 6m
MAX ASPIRAZIONE NEG. INVASATA:9,8 m
MAX PASSAGGIO DI SOLIDI: 3 mm
RUMOROSITA':65 dB
CILINDRATA PER CICLO: 30cc
VISCOSITA' MAX:12.000 cps
ATEXzona 2: EX II3/3 GD c IIB T135°C

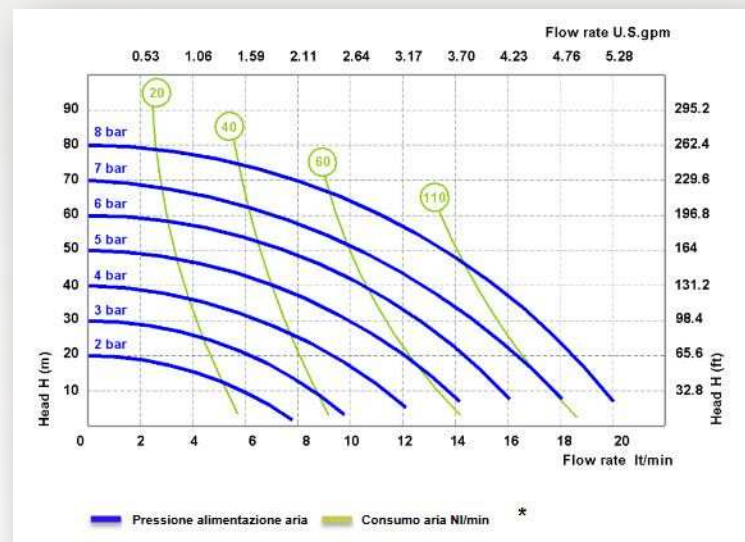

Water Treatment

Accessori



AIR REGULATION KIT

Adjust and set air pressure and air flow-rate with a filter regulator, pressure gauge and air valve unit.



SWITCH VALVES

Remotely start and stop with a solenoid or pneumatic valve for the pump's air.



STROKE COUNTER

Count the number of strokes, connected to a control. It allows various type of monitoring.



DIAPHRAGM FAILURE DETECTION

The Electronic Leak Detector provide a signal via warning lights, an audible alarm, and the pump can be shut down.



PNEUMATIC BATCH CONTROL "START & STOP"

Pneumatic batcher can control any pump allowing you to set the cycles amount.



BASKET STRAINER FILTERS IN PP

Installed on the suction of the pumps, protects them from suspended solids and impurity.



INOX TROLLEY

It makes transportable pumps



ANTI VIBRATION FEET KIT

Reduces physical vibration from AOD pump operation.



PP, PVDF, ALU, SS NOZZLE

Dispenser to delivery control and batching.



VALVES, FITTINGS AND CONNECTIONS IN PP, PVC, INOX



REINFORCED PVC HOSE

With metal reinforcement for suction/discharge, also food-grade.



FLANGE CONNECTION KIT

Adapt a pump from BSP type connection to flanges with this kit.